

# Counter-Seal CS24

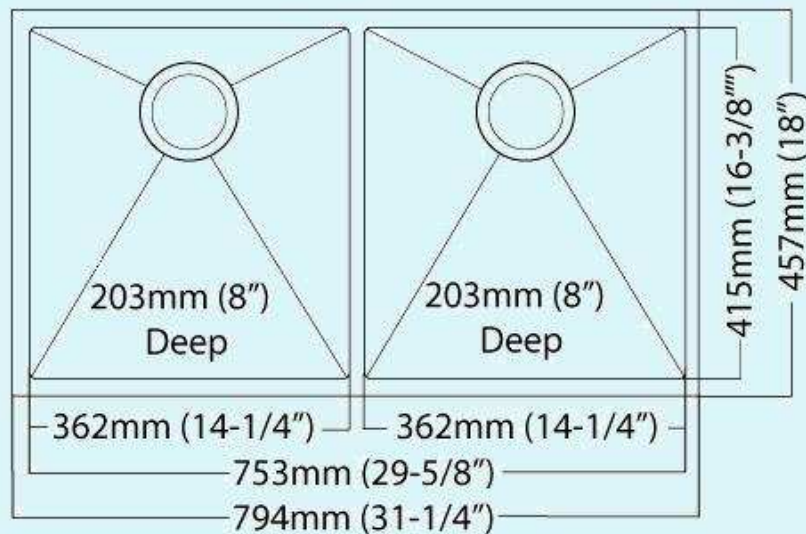

Double-bowl undermount sink  
Rear drain  
Made in China

Two equal-sized bowls:  
16-3/8" FB x 14-1/4" LR x 8" DP



Counter-Seal sinks are manufactured from heavy 18-gauge, premium 304 stainless steel. They can be undermounted in granite, engineered stone, solid surface and, when using the Counter-Seal® System, in laminate and tile. All sink models are approved to various North American plumbing codes. Strainers are sold separately.

FB=Front to Back; LR=Left to Right; DP=Deep

# Counter-Seal CS25



Single bowl undermount sink  
Rear drain  
Made in China

16-3/8" FB x 29-5/8" LR x 8" DP

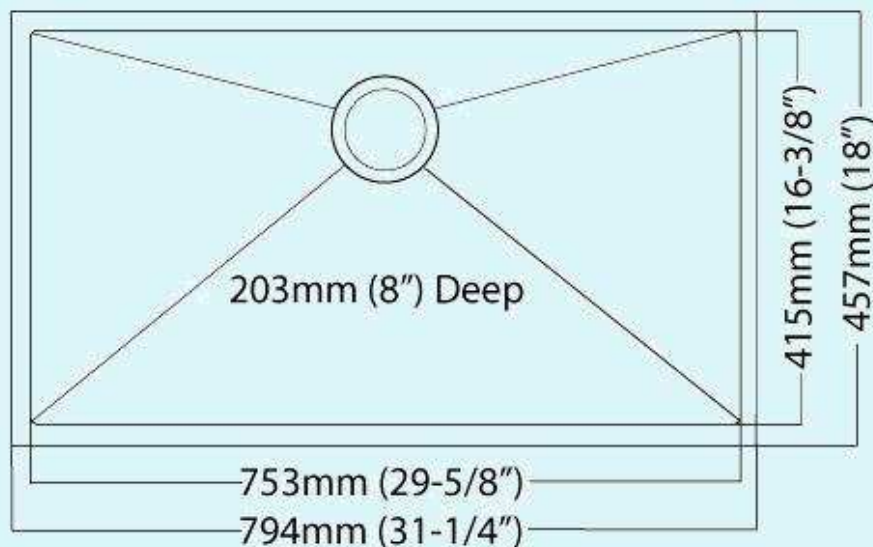

Counter-Seal sinks are manufactured from heavy 18-gauge, premium 304 stainless steel. They can be undermounted in granite, engineered stone, solid surface and, when using the Counter-Seal® System, in laminate and tile. All sink models are approved to various North American plumbing codes. Strainers are sold separately.

FB=Front to Back; LR=Left to Right; DP=Deep

# Counter-Seal CS26L



Double-bowl undermount sink  
Small bowl on the left  
Rear drain  
Made in China

Large bowl: 16-3/8" FB x 18" LR x 8" DP  
Small bowl: 16-3/8" FB x 10-1/2" LR x 8" DP

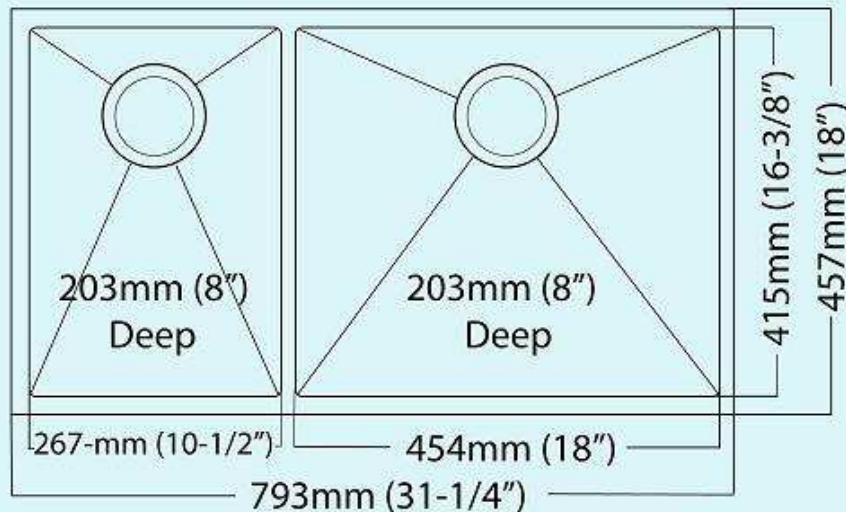

Counter-Seal sinks are manufactured from heavy 18-gauge, premium 304 stainless steel. They can be undermounted in granite, engineered stone, solid surface and, when using the Counter-Seal® System, in laminate and tile. All sink models are approved to various North American plumbing codes. Strainers are sold separately.

FB=Front to Back; LR=Left to Right; DP=Deep

# Counter-Seal CS26R



Double-bowl undermount sink  
Small bowl on the right  
Rear drain  
Made in China

Large bowl: 16-3/8" FB x 18" LR x 8" DP  
Small bowl: 16-3/8" FB x 10-1/2" LR x 8" DP

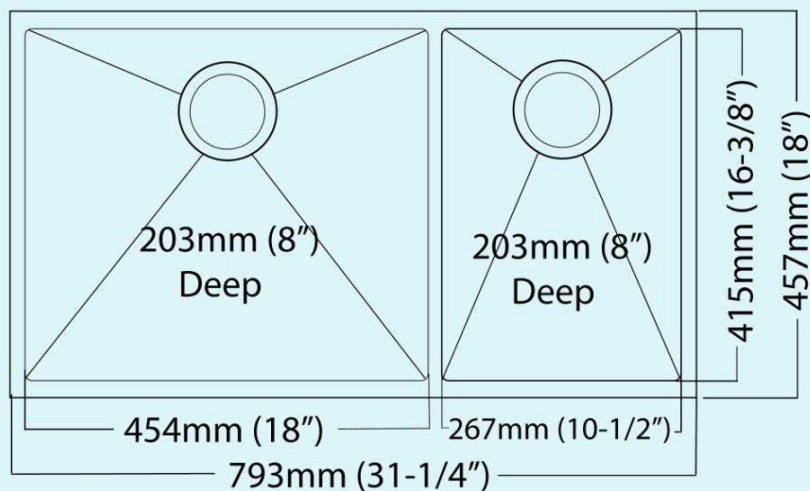

Counter-Seal sinks are manufactured from heavy 18-gauge, premium 304 stainless steel. They can be undermounted in granite, engineered stone, solid surface and, when using the Counter-Seal® System, in laminate and tile. All sink models are approved to various North American plumbing codes. Strainers are sold separately.

FB=Front to Back; LR=Left to Right; DP=Deep

# Counter-Seal CS1618



Large bar sink  
Centre drain  
Made in USA

15-3/4" FB x 14"LR x 8"DP

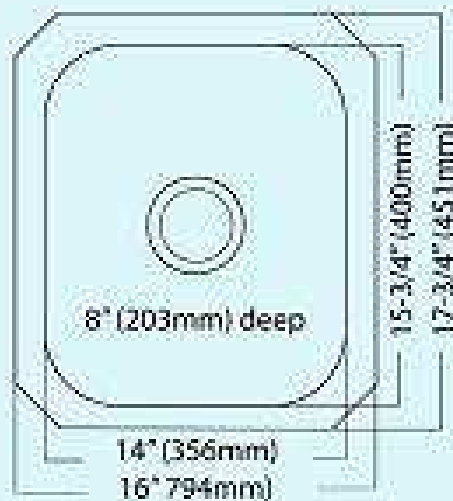

Counter-Seal sinks are manufactured from heavy 18-gauge, premium 304 stainless steel. They can be undermounted in granite, engineered stone, solid surface and, when using the Counter-Seal® System, in laminate and tile. All sink models are approved to various North American plumbing codes. Strainers are sold separately.

FB=Front to Back; LR=Left to Right; DP=Deep

# Counter-Seal CS1813/7



Undermount bar sink  
Rear drain  
16" FB x 10-1/2" LR x 7" DP  
Made in Canada

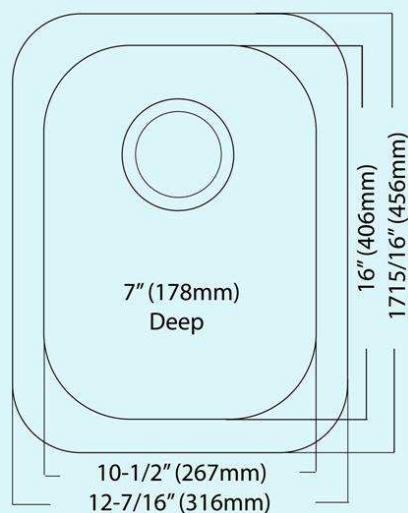

Counter-Seal sinks are manufactured from heavy 18-gauge, premium 304 stainless steel. They can be undermounted in granite, engineered stone, solid surface and, when using the Counter-Seal® System, in laminate and tile. All sink models are approved to various North American plumbing codes.

Strainers are sold separately.

FB=Front to Back; LR=Left to Right; DP=Deep

# Counter-Seal CS3118



Double-bowl undermount sink  
Centre drain  
Made in USA

Two equal-sized bowls:  
15-3/4" FB x 14"LR x 8"DP

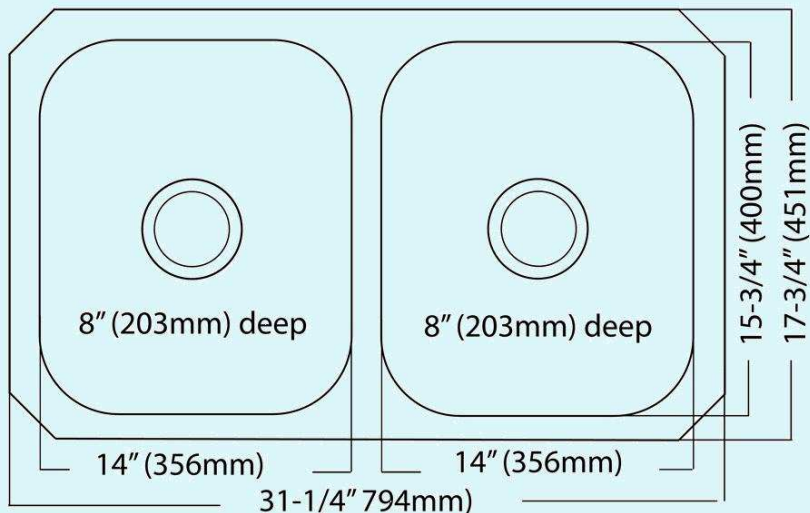

Counter-Seal sinks are manufactured from heavy 18-gauge, premium 304 stainless steel. They can be undermounted in granite, engineered stone, solid surface and, when using the Counter-Seal® System, in laminate and tile. All sink models are approved to various North American plumbing codes. Strainers are sold separately.

FB=Front to Back; LR=Left to Right; DP=Deep

# Counter-Seal CS1925/9



Single undermount sink  
Rear drain  
Made in Canada

17" FB x 23"LR x 9"DP

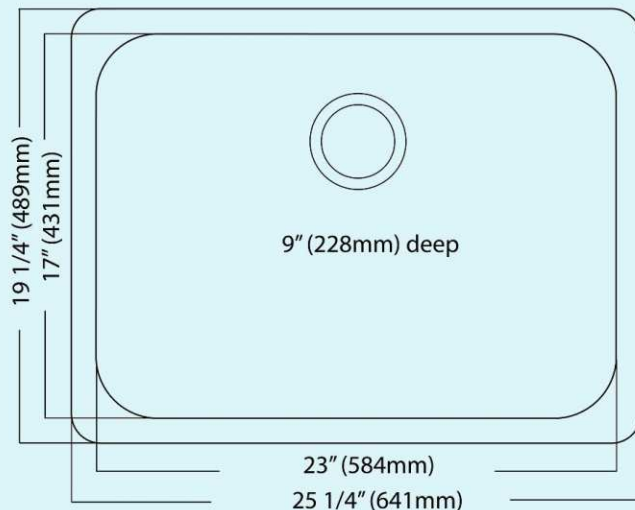

Counter-Seal sinks are manufactured from heavy 18-gauge, premium 304 stainless steel. They can be undermounted in granite, engineered stone, solid surface and, when using the Counter-Seal® System, in laminate and tile. All sink models are approved to various North American plumbing codes. Strainers are sold separately.

FB=Front to Back; LR=Left to Right; DP=Deep



# Counter-Seal CS1931/9



Double-bowl undermount sink  
Rear drain  
Made in Canada

Two equal-sized bowls:  
16" FB x 14" LR x 9" DP

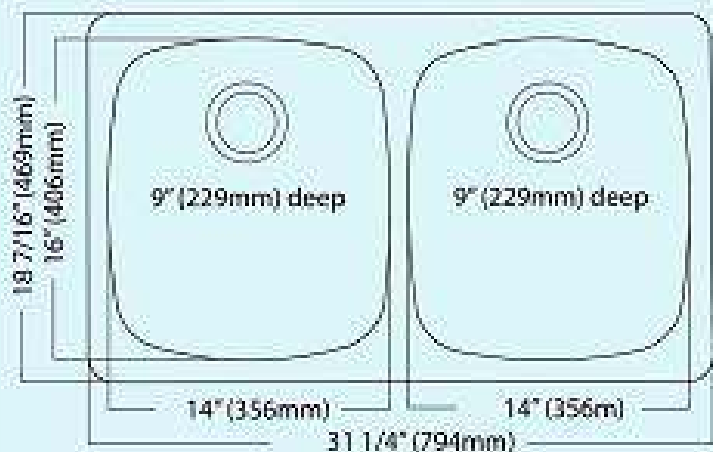

Counter-Seal sinks are manufactured from heavy 18-gauge, premium 304 stainless steel. They can be undermounted in granite, engineered stone, solid surface and, when using the Counter-Seal® System, in laminate and tile. All sink models are approved to various North American plumbing codes. Strainers are sold separately.

FB=Front to Back; LR=Left to Right; DP=Deep

# Counter-Seal CS1932R/9



Double-bowl undermount sink  
with small bowl on the right

Rear drain

Made in Canada

Large bowl: 17" FB x 14" LR x 9" DP  
Small bowl: 16" FB x 14" LR x 8" DP

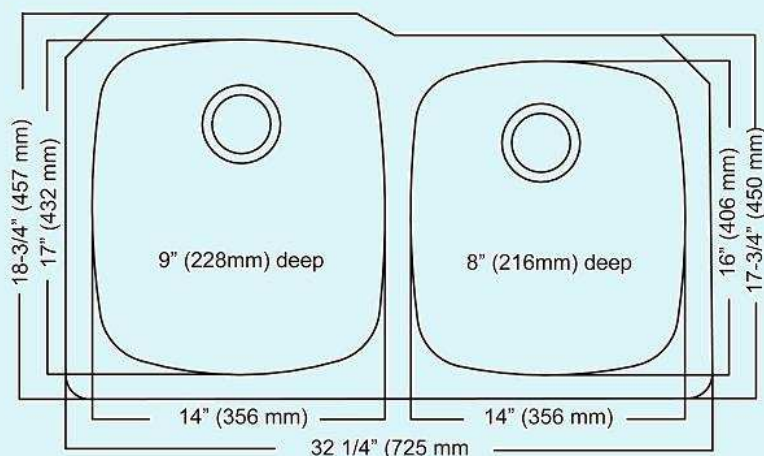

Counter-Seal sinks are manufactured from heavy 18-gauge, premium 304 stainless steel. They can be undermounted in granite, engineered stone, solid surface and, when using the Counter-Seal® System, in laminate and tile. All sink models are approved to various North American plumbing codes.

Strainers are sold separately.

FB=Front to Back; LR=Left to Right; DP=Deep

# Counter-Seal CS2115



Single undermount sink  
Centre drain  
Made in USA

15-3/4" FB x 21"LR x 8"DP

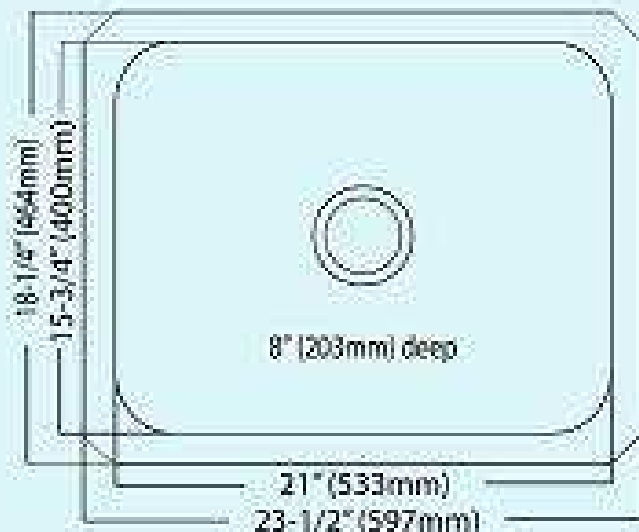

Counter-Seal sinks are manufactured from heavy 18-gauge, premium 304 stainless steel. They can be undermounted in granite, engineered stone, solid surface and, when using the Counter-Seal® System, in laminate and tile. All sink models are approved to various North American plumbing codes. Strainers are sold separately.

FB=Front to Back; LR=Left to Right; DP=Deep

# Counter-Seal CS2123/9



Single undermount sink  
Rear drain  
Made in Canada

18-7/8" FB x 21-1/4" LR x 9" DP

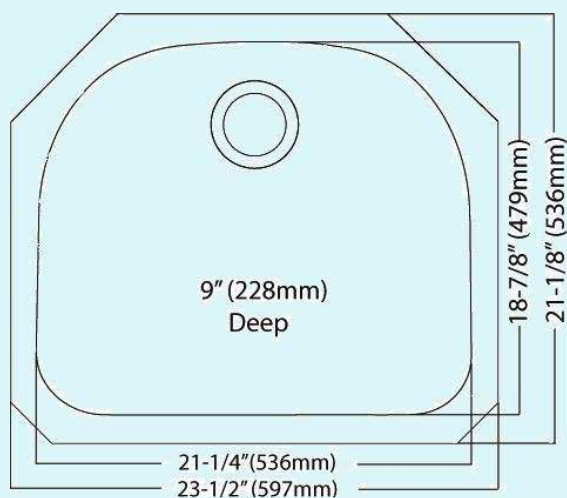

Counter-Seal sinks are manufactured from heavy 18-gauge, premium 304 stainless steel. They can be undermounted in granite, engineered stone, solid surface and, when using the Counter-Seal® System, in laminate and tile. All sink models are approved to various North American plumbing codes.

Strainers are sold separately.

FB=Front to Back; LR=Left to Right; DP=Deep

# Counter-Seal CS2131R/9



Double Undermount Sink with  
Small bowl right  
Rear drain  
Made in Canada

Double undermount sink with  
small bowl right  
Rear drain

Large: 18-5/16" FB x 17-3/4" LR x 9" DP  
Small: 16-1/16" FB x 10-1/2" LR  
x 8" DP

Counter-Seal sinks are manufactured from heavy 18-gauge, premium 304 stainless steel. They can be undermounted in granite, engineered stone, solid surface and, when using the Counter-Seal® System, in laminate and tile. All sink models are approved to various North American plumbing codes.

Strainers are sold separately.

FB=Front to Back; LR=Left to Right; DP=Deep

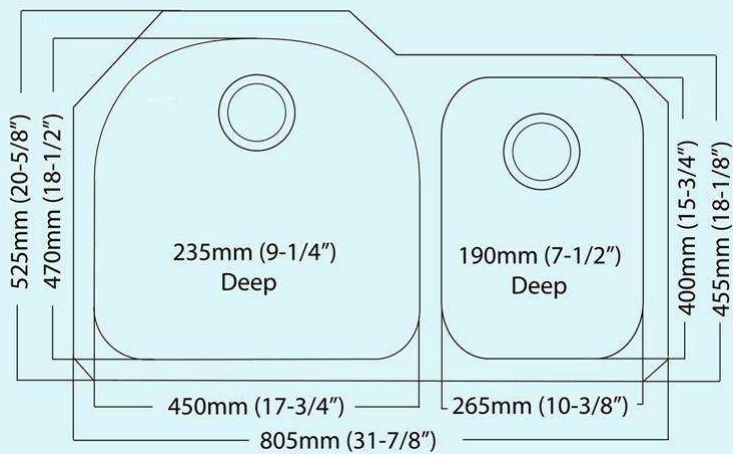

# Counter-Seal CS312010R



Double-bowl undermount sink  
With smaller bowl on the right  
Centre drain  
Made in USA

Large bowl: 18" FB x 13-1/2 LR x 10" DP  
Small bowl: 15-3/4" FB x 14" LR x 8" DP

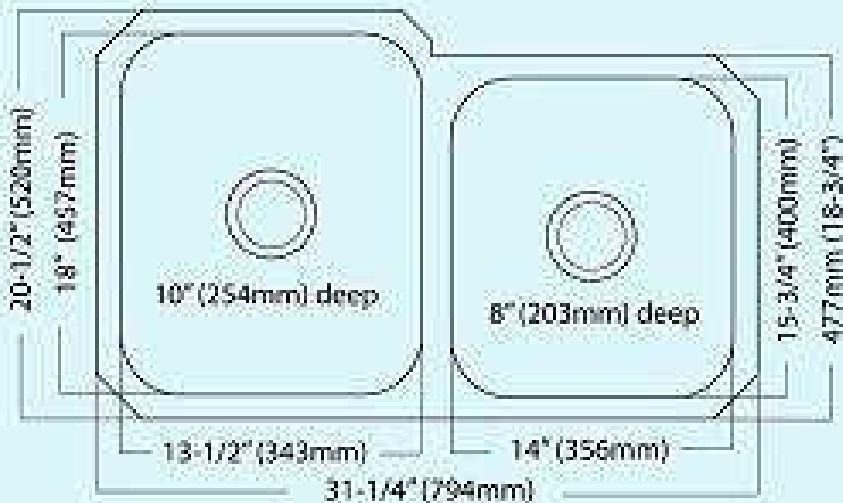

Counter-Seal sinks are manufactured from heavy 18-gauge, premium 304 stainless steel. They can be undermounted in granite, engineered stone, solid surface and, when using the Counter-Seal® System, in laminate and tile. All sink models are approved to various North American plumbing codes. Strainers are sold separately.

FB=Front to Back; LR=Left to Right; DP=Deep

# Counter-Seal CSVU



Ceramic Vanity Sink  
Available in White, Black and Cream  
Made in China

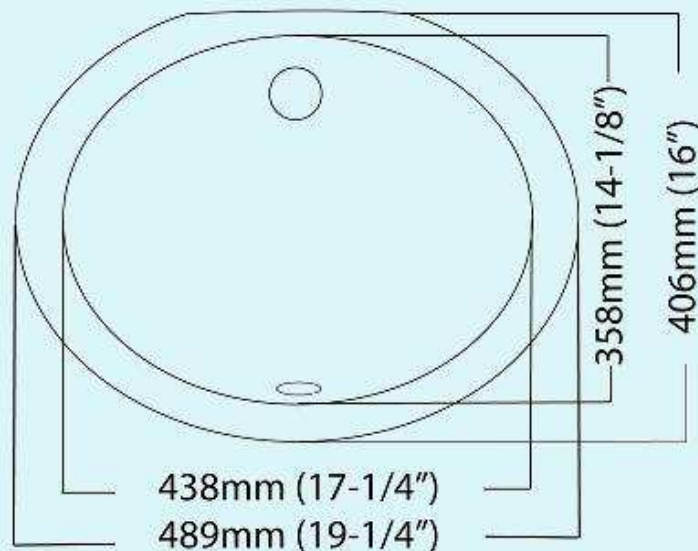

Inside dimensions:  
14-1/8" FB x 17-1/4" LR x 6-1/2" DP

They can be undermounted in granite, engineered stone, solid surface and, when using the Counter-Seal® System, in laminate and tile. All sink models are approved to various North American plumbing codes.

FB=Front to Back; LR=Left to Right; DP=Deep